



# ULTF-37i

## ULT TECHNICAL SPECIFICATIONS



DIMENSIONS		VALUE
Dimension HxWxD (D incl. handle)		631x630x675 (745)
Dimension inner HxWxD		433x439x271
Weight Gross/Net, kg		70 / 59
Package weight		11
Packaging dimensions HxWxD		-
Material inner cabinet		Stainless steel
Material outer cabinet		Painted Steel
Insulation type		Polyurethane with Cyclopentane
Insulation thickness		80
Type of packaging		Cardboard, EPS, PE, wood
Mobility		Standard: Adjustable Feet / Option: Castors
FEATURES		VALUE
Lock		<input checked="" type="checkbox"/>
LED light		<input checked="" type="checkbox"/>
Battery backup		<input checked="" type="checkbox"/>
Porthole		<input checked="" type="checkbox"/>
Porthole size		20 mm
Dry contact		<input checked="" type="checkbox"/>
Door reversibility		<input type="checkbox"/>
Vacuum valve		<input checked="" type="checkbox"/>
VIP (Vacuum Insulated Panel)		<input checked="" type="checkbox"/>
STORAGE		VALUE
Capacity (L)		37
ALARMS		VALUE
High / Low temperature		<input checked="" type="checkbox"/>
Open door		<input checked="" type="checkbox"/>
Power failure		<input checked="" type="checkbox"/>
Probe failure		<input checked="" type="checkbox"/>
COOLING		VALUE
Refrigerant		Nature R / 96
Noise		< 48
Voltage		100-240 V
Frequenze		50/60 Hz
Temperature range		-20 / -86
Ambient condition		25 °C



# ULTF-37i

## ULT TECHNICAL SPECIFICATIONS

BIOMEDICAL

OPERATING CONDITIONS		
Voltage/Frequency	Voltage/Hz	100-240 V, 50/60Hz
Max Ambient	°C	32
Max Humidity	% rh	65
PERFORMANCE	UNIT	VALUE
<b>All data in RT25°C</b>		
Temperature Range	°C	-20 to -86
Uniformity in performance - difference between top and bottom	°C	+/- 2,5
Pull down time	Minutes	84 min. to -75°C
Hold over time	Minutes	N/A
Noise	dB	< 48
Energy Consumption, kWh / 24h	kWh/24h	2,94 kWh/24h Set -80
Energy year	kWh/year	1186,6kWh/y Set -82°C
Instant Power Consumption	kW	PD 0,300/Stable 0,190
Heat Rejection	W	N/A
U-Value	W/m <sup>2</sup> K	N/A
COOLING COMPONENTS		VALUE
Refrigerant/Amount (gram)		Nature R 2/96gr
Number of compressors	pcs	1
Varibel speed compressor	Yes/No	Yes
Internal air distribution (type of)		Static
Evaporator Fan	Yes/No/Variable	No
Condenser Fan	Yes/No/Variable	Yes
Number of probes	pcs	2
Defrost	Yes/No	No
CONTROLLER		VALUE
Controller	y/n/optional	yes
Controller type		i-Care touch
USB Connection	y/n	yes
Data connection	USB	yes
Controller abilities		logging of data & alarms
Controller languages		EN, DE, FR
Temperature curve in controller	y/n	yes



# ULTF-37i

## ULT TECHNICAL SPECIFICATIONS

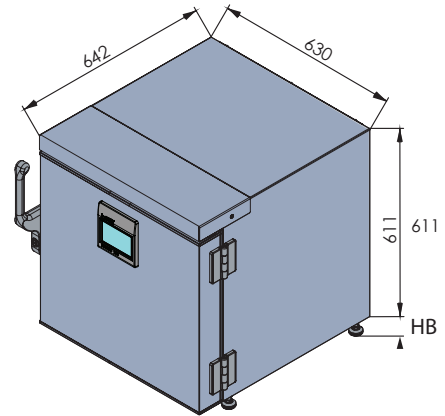
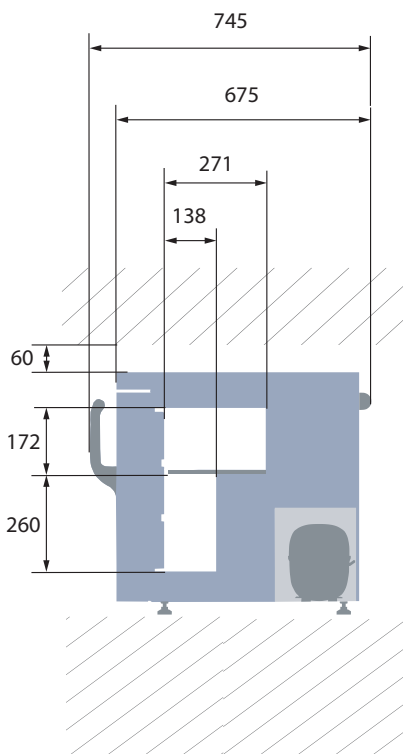
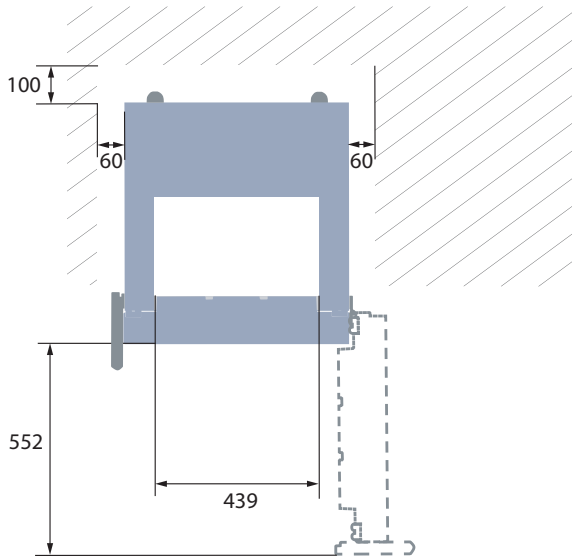

### DIMENSIONS

Height, mm	631
Width, mm	630
Depth, mm	675
Depth incl. handle, mm	745

All measurements in mm.

HB: Height of base  
(HB is adjustable when given value is xx-xx)

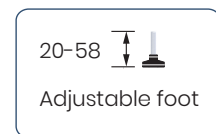
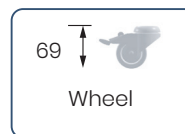



# ULTF-37i

## ULT TECHNICAL SPECIFICATIONS

### SENSOR POSITION

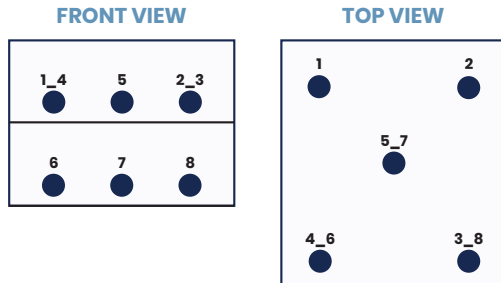

### MODEL ULTF-37i

<b>Test type</b>	8-point test
<b>Test environment</b>	Controlled conditions, empty cabinet
<b>Ambient temperature</b>	20°C
<b>Humidity</b>	60%
<b>Set-point</b>	-82°C
<b>Sensor used</b>	25gr tinned brass formed as a cylinder with a diameter of 15,2 mm
<b>Installation</b>	Appliance installed according to instruction manual conditions
<b>Refrigerant</b>	Nature R 2

### SENSOR TEMPERATURE

Sensor position	P1	P2	P3	P4	P5	P6	P7	P8
Max	-79,7	-80,2	-80,1	-79,9	-80	-83,1	-83,1	-84,6
Avg.	-80	-80,5	-80,4	-80,2	-80,3	-83,5	-83,6	-85
Min.	-80,4	-81	-80,8	-80,5	-80,7	-84,1	-84,1	-85,4

### WARM UP & PULL DOWN

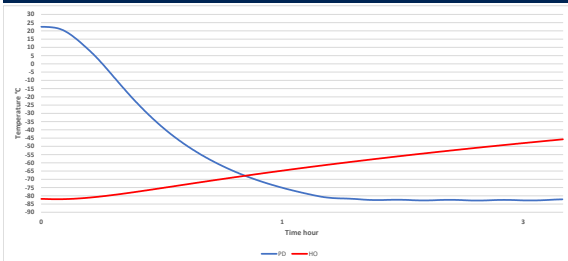

### CYCLIC OPERATION

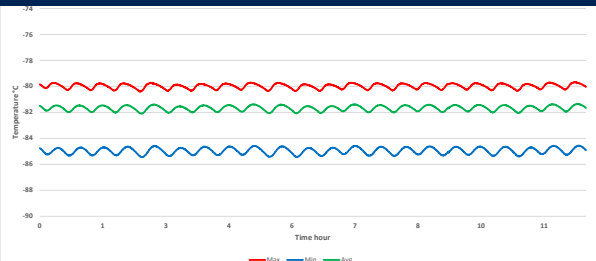

### TYPICAL PERFORMANCE IN AMBIENT 20°C - EMPTY CABINET

<b>Avg. cabinet temperature</b>	-81,7°C
<b>Peak variation from set-point</b>	+/- 2,5°C
<b>Stability in avg.</b>	0,5°C
<b>1 min. door open recovery to -75°C avg. temperature</b>	20 min.
<b>Cycle rate on/off</b>	25,7 / 6,7 min.
<b>Duty cycle</b>	78,7%
<b>Energy consumption - Normal mode</b>	3,25 kWh/day
<b>Energy consumption - Energy saving mode</b>	2,92 kWh/day
<b>Pull down time to -75°C avg. temperature</b>	84 min.
<b>Hold over time from -82°C to -60°C</b>	105 min.
<b>Heat rejection</b>	306 W